



Advanced Technology. Simple Solutions.

250A SINGLE-PHASE CAMPGROUND DISTRIBUTION CENTER

CGA1-250

The CGA1-250-240 campground distribution center is a free-standing, all-encompassing, pad-mount enclosure used primarily for power distribution in campgrounds. The weatherproof design is ideal for outdoor use. Standard PC113 Parks Green powder coat paint provides a durable finish.

Features / Specifications

- Steel construction
- CSA Type 3R rated
- 2-pole main breaker with lock off
- Service entrance rated main breaker
- 10 kAIC rated bolt-on breakers
- Louvers with bug screen
- Padlockable 3-point handle
- Standard 120/240 V single-phase
- Removable lifting ears
- 250 MCM - #6 load termination lugs
- Complete factory wiring to load termination lugs
- Ground bar with lugs for grounding circuits
- Pad-mount design
- PC113 Parks Green powder coat finish



Options

- Photocell and HOA
- Service receptacle
- Lighting control
- 100% rated main breaker
- Sub-breakers as required
- Meter base
- Heater and thermostat
- Cooling fan and controls
- Up to 22 kAIC sub-breakers
- Distribution lugs up to 600 MCM
- Custom powder coat colours

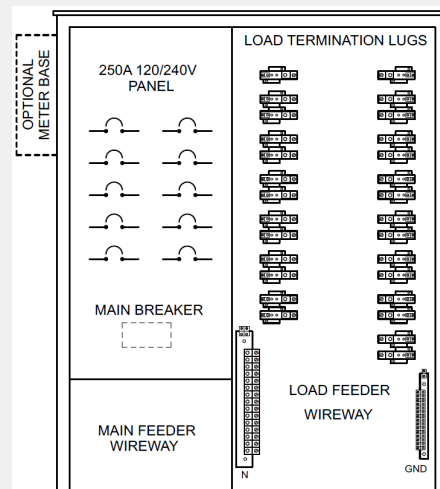

PART NUMBER	CIRCUIT	DIMENSIONS		
		HEIGHT	WIDTH	DEPTH
CGA1-250-240-18-QT	18 A	60 in	48 in	12 in
CGA1-250-240-30-QT	30 A	60 in	48 in	16 in
CGA1-250-240-42-QT	42 A	72 in	60 in	18 in

Contact Valid for all available options.