



Advanced Technology. Simple Solutions.

AIR VALVE ENCLOSURE

HRV

The Air Valve Enclosure is designed to provide both front and top access to an air valve installation. The certified assembly includes the main and branch breaker as well as pipe clamp and heat trace cable.

Features / Specifications

- 1/8 in. - 5052 marine-grade aluminum
- CSA Type 3R rated
- Insulated with 1- 1/2 ft foil-back insulation
- Stainless steel hinges
- Removeable drainage/ventilation panel
- Designed to fit on precast base
- PC101 Grey powder coat with PC119 anti-graffiti coating

Options

- VWHC16146, Type 3R junction box - 16 in. H x 14 in. W x 6 in. D
- 40 ft heat trace cable
- 1P 15A GFI breaker mounted in junction box
- Pipe Clamp - sized per part number

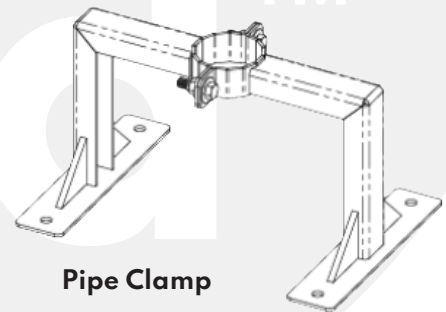
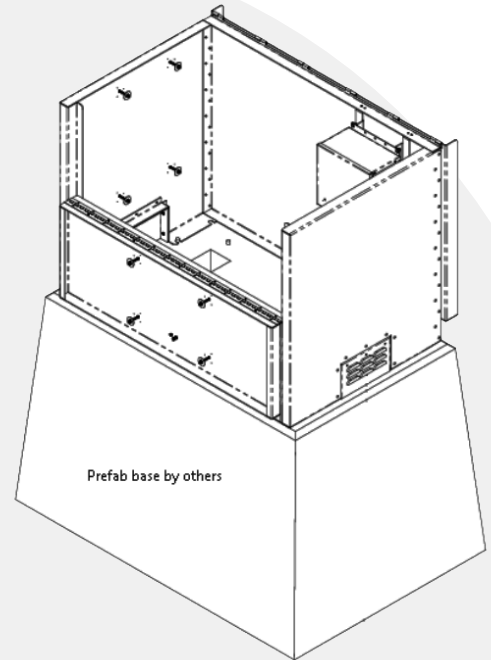

BASE PART NUMBER	HEIGHT	WIDTH	DEPTH	COMES WITH 1 IN. PIPE CLAMP	COMES WITH 2 IN. PIPE CLAMP	COMES WITH 4 IN. PIPE CLAMP	COMES WITH 6 IN. PIPE CLAMP
HRV344227	34 in	42 in	27 in	HRV344227-1	HRV344227-2	HRV344227-4	HRV344227-6
HRV344630	34 in	46 in	30 in	HRV344630-1	HRV344630-2	HRV344630-4	HRV344630-6
HRV604630	60 in	46 in	30 in	HRV604630-1	HRV604630-2	HRV604630-4	HRV604630-6